



10A PC board type



10A TM type



60A Screw terminal type



80A Connector type



300A Connector type

### FEATURES

#### 1. High-voltage, high-current control capable

400V DC high-voltage switching cutoff has been achieved thanks to a sealed construction with mixed hydrogen gas and the magnetic arc motion through use of a permanent magnet.

#### 2. Compact & Low Operating Sound

By using a capsule contact mechanism that is enclosed with hydrogen gas, high-capacity cutoff is possible even with a tiny contact gap. There is little operating sound, which does not change even when large currents are cut off.

#### 3. Arc space unnecessary

The enclosure box can be made smaller thanks to an arc-space-free construction from which the arc will not get out.

#### 4. Safety

Since the contacts are enclosed in a sealed capsule structure, the arc will not get out, which ensures safety.

#### 5. High contact reliability

The contact part is hermetically sealed with H<sub>2</sub> mixed gas, hence the contact resistance remains stable regardless of the ambient conditions.

#### 6. Mounting direction is not specified

The weight of the movable parts is light, and also the restoring force is large, hence the relay is relatively unaffected by gravity.

#### 7. Wide selection of models available.

Types include PC board type, TM type (10A), screw terminal type (60A), and connector type (80A and 300A).

#### 8. Standard compliance

The 60A type is UL and C-UL standard certified.

### TYPICAL APPLICATIONS

1. Cogeneration systems
2. Battery inspection and testing equipment (charge and discharge control)
3. Construction machinery
4. AGV (Automatic guided vehicle) (Unmanned transport carts)
5. Welding equipment
6. Inverter control
7. Solar power generation systems
8. Elevator, etc.

### ORDERING INFORMATION

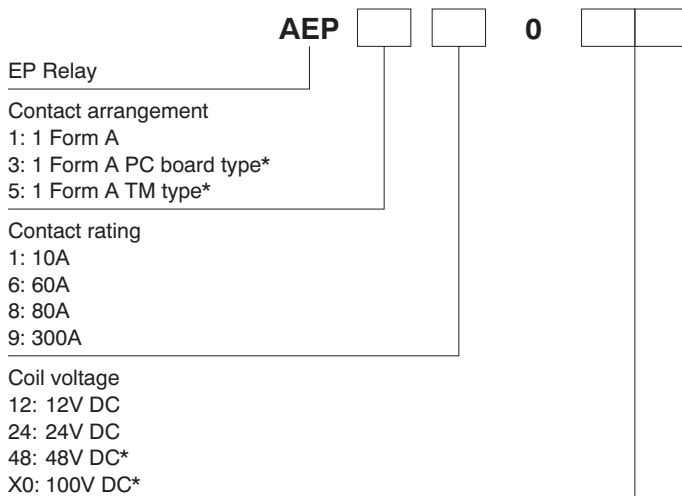

Note: \*10A type only

## TYPES

Ttpe	Nominal coil voltage	Contact arrangement	Part No.	Packing quantity	
				Carton	Case
10A PC board type	12V DC	1 Form A	AEP31012	25pcs.	100pcs.
10A TM type			AEP51012	25pcs.	100pcs.
60A			AEP16012	1pc.	20pcs.
80A Connector type*			AEP18012	1pc.	20pcs.
300A Connector type*			AEP19012	1pc.	5pcs.
10A PC board type	24V DC		AEP31024	25pcs.	100pcs.
10A TM type			AEP51024	25pcs.	100pcs.
60A			AEP16024	1pc.	20pcs.
80A Connector type*			AEP18024	1pc.	20pcs.
300A Connector type*			AEP19024	1pc.	5pcs.
10A PC board type	48V DC		AEP31048	25pcs.	100pcs.
10A TM type			AEP51048	25pcs.	100pcs.
10A PC board type	100V DC		AEP310X0	25pcs.	100pcs.
10A TM type			AEP510X0	25pcs.	100pcs.

Notes: \* One female connector lead wire for connecting is packaged with the 80A and 300A connector types.  
 -Specifications: Housing: Yazaki 7283-1020 (light gray); Lead wire: 0.5 mm<sup>2</sup> dia. and 300±10 mm length  
 Lead wire coating color: Pin No. 1: white; Pin No. 2: green

## RATING

## 1. Coil data

Type	Nominal coil voltage	Pick-up voltage (at 20°C 68°F)	Drop-out voltage (at 20°C 68°F)	Nominal coil current [±10%] (at 20°C 68°F)	Nominal operating power (Nominal voltage applied to the coil, at 20°C 68°F)	Max. allowable voltage
10A	12V DC	75%V or less of nominal voltage (Initial)	8%V or more of nominal voltage (Initial)	0.103A	Max. 1.4W	130%V of nominal voltage
60A				0.415A	Max. 5W	
80A				0.375A	Max. 5W	
300A				3.3A (during peak)	When input: 40 W max. (0.1 sec. from time of input) When retained: 4 W max.	
10A	24V DC			0.052A	Max. 1.4W	
60A				0.208A	Max. 5W	
80A				0.188A	Max. 5W	
300A				1.85A (during peak)	When input: 45 W max. (0.1 sec. from time of input) When retained: 4 W max.	
10A	48V DC			0.026A	Max. 1.4W	
10A	100V DC			0.012A		

\*When using a DC power supply use one that has a leeway of at least 150% current capacity.

2. Specifications

Characteristics	Item	Specifications			
		10A type	60A type	80A type	300A type
Rating	Arrangement	1 Form A	1 Form A	1 Form A	1 Form A
	Nominal switching capacity (resistive load)	10A 400V DC	60A 400V DC	80A 400V DC	300A 400V DC
	Short term current	15A (2min), 30A (30s)	120A (15min) (harness wire: 15mm <sup>2</sup> )		400A (10min) (harness wire: 100mm <sup>2</sup> )
	Max. cut-off current	—	600A 300V DC (5 cycles)* <sup>2</sup>	800A 300V DC (1 cycle)* <sup>2</sup>	2,500A 300V DC (3 cycles)* <sup>3</sup>
	Overload opening/closing rating	30A 400V DC (Min. 50 cycles)* <sup>2</sup>	180A 400V DC (Min. 100 cycles)* <sup>2</sup>	120A 400V DC (Min. 50 cycles)* <sup>2</sup>	600A 400V DC (Min. 300 cycles)
	Reverse cut-off current	-10A 200V DC (Min. 2.5×10 <sup>3</sup> cycles)* <sup>2</sup>	-60A 200V DC (Min. 1,000 cycles)* <sup>2</sup>	-120A 200V DC (Min. 50 cycles)* <sup>2</sup>	-300A 200V DC (Min. 100 cycles)
	Min. switching capacity	1A 6V DC	—	—	—
	Contact voltage drop	Max. 0.5V (When current [is 10A per 1] contact set)	Max. 0.1V (When current [is 60A per 1] contact set)	Max. 0.067V (By voltage drop 6V DC 20A)	Max. 0.06V (When current [is 300A per 1] contact set)
Electrical characteristics	Insulation resistance (Initial)		Min. 100MΩ (at 500V DC) Measurement at same location as "Initial breakdown voltage" section.		
	Breakdown voltage (Initial)	Between open contacts	2,500 Vrms for 1min. (Detection current: 10mA.)		
		Between contact and coil	2,500 Vrms for 1min. (Detection current: 10mA.)		
	Operate time (at 20°C 68°F)	Max. 50ms (Nominal voltage applied to the coil, excluding contact bounce time.)			Max. 30ms (Nominal voltage applied to the coil, excluding contact bounce time.)
	Release time (at 20°C 68°F)	Max. 30ms (After the nominal operation voltage stops)			Max. 10ms (After the nominal operation voltage stops)
Mechanical characteristics	Shock resistance	Functional	Min. 196 m/s <sup>2</sup> (Half-wave pulse of sine wave: 11 ms; detection time: 10μs.)		
		Destructive	Min. 490 m/s <sup>2</sup> (Half-wave pulse of sine wave: 6 ms.)		
	Vibration resistance	Functional	10 to 200Hz, acceleration 43m/s <sup>2</sup> constant (Detection time: 10μs.)		
		Destructive	10 to 200Hz, acceleration 43m/s <sup>2</sup> constant (3 directions, each 4 hours)		
Expected life	Mechanical	Min. 10 <sup>5</sup>	Min. 2×10 <sup>5</sup>		
	Electrical	7.5×10 <sup>4</sup> 10A 400V DC* <sup>2</sup> L/R ≤ 1ms	3×10 <sup>3</sup> 60A 400V DC* <sup>2</sup> L/R ≤ 1ms	10 <sup>3</sup> 80A 400V DC* <sup>2</sup> L/R ≤ 1ms	10 <sup>3</sup> 300A 400V DC L/R ≤ 1ms
Conditions	Conditions for operation, transport and storage* <sup>1</sup> Ambient temperature: -40°C to +80°C -40°F to +176°F (Storage: Max. 85°C 185°F), Humidity: 5 to 85% R.H. (Not freezing and condensing at low temperature)				
Unit weight	Approx. 80 g 2.820oz		Approx. 340 g 12.00oz	Approx. 400 g 14.11oz	Approx. 750 g 26.46oz

Notes:\*<sup>1</sup> The upper operation ambient temperature limit is the maximum temperature that can satisfy the coil temperature rise value.  
Refer to 6. Conditions for operation, transport and storage mentioned in [AMBIENT ENVIRONMENT \(p. 19, Relay Technical Information\)](#).  
\*<sup>2</sup> Conditions: Varistor used for coil surge absorption. Note: if a diode is used the life will be lower.  
\*<sup>3</sup> Condition: Switches rated number of 10 cycles each time there is a 2,500A cutoff.

REFERENCE DATA

1.-(1) Ambient temperature characteristics (10A type)

Tested sample: 10A type EP relay, 3pcs.

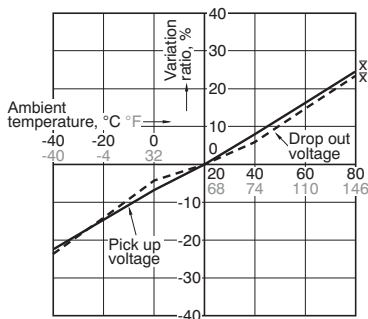

1.-(2) Ambient temperature characteristics (60A type)

Tested sample: 60A type EP relay, 3pcs.

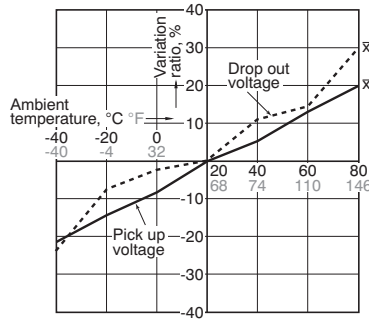

1.-(3) Ambient temperature characteristics (80A type)

Tested sample: 80A type EP relay, 3pcs.

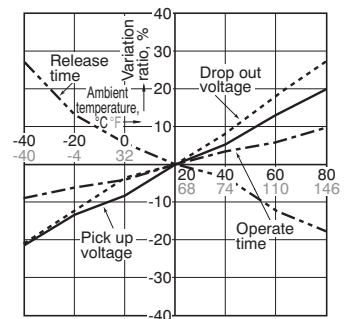

## 1.-(4) Ambient temperature characteristics (300A type)

Tested sample: 300A type EP relay, 3pcs.

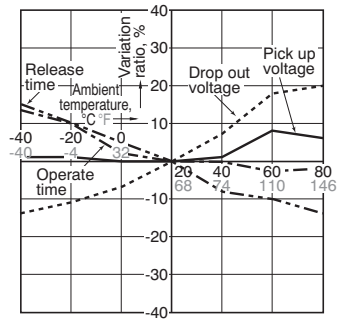

## 2.-(1) Max. value for switching capacity (10A and 60A types)

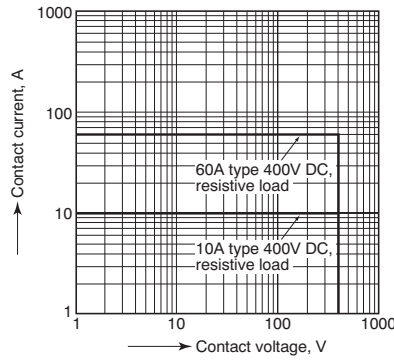

## 2.-(2) Max. value for switching capacity (80A and 300A types)

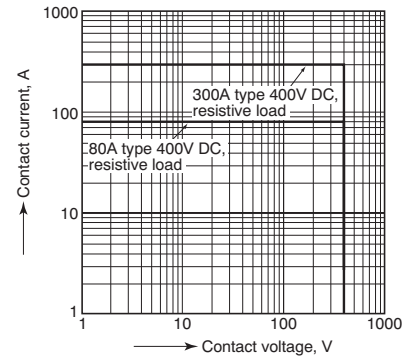

## 3.-(1) Switching life curve (10A type)

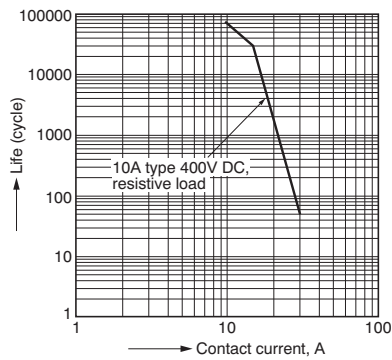

## 3.-(2) Switching life curve (60A type)

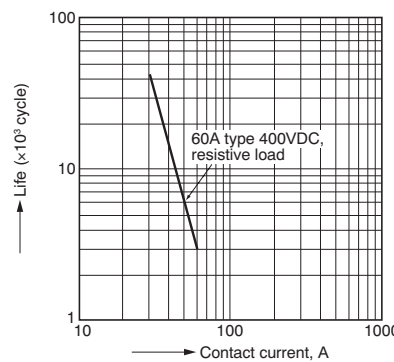

## 3.-(3) Switching life curve (80A type)

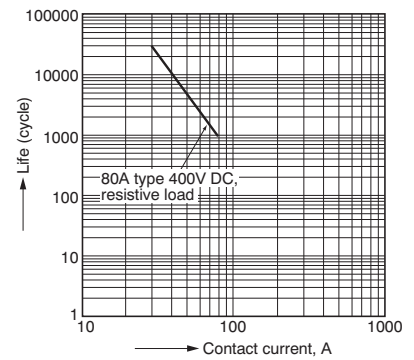

## 3.-(4) Switching life curve (300A type)

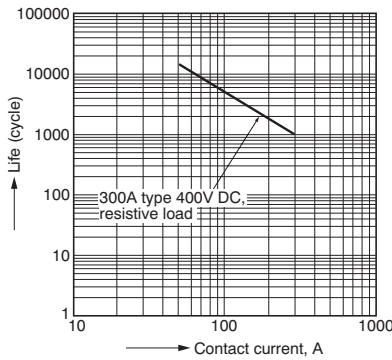

## 4. Cut-off curve (forward direction)

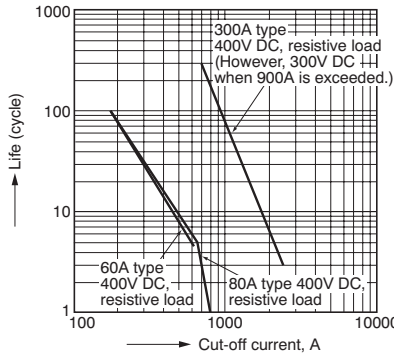

## 5.-(1) Carrying performance curve (80°C) (10A and 60A types)

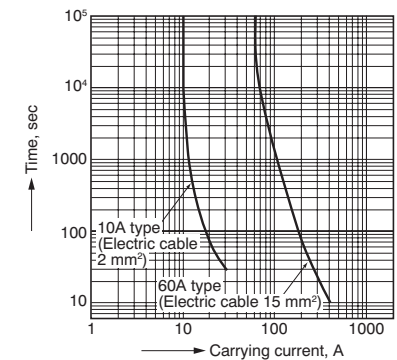

## 5.-(2) Carrying performance curve (80°C) (80A and 300A types)

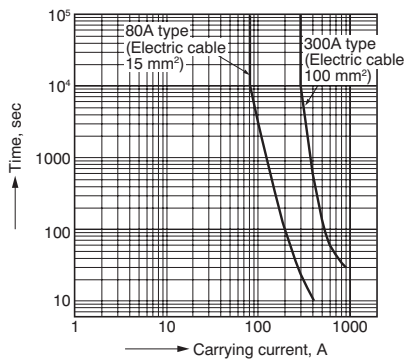

# DIMENSIONS (Unit: mm inch)

## 1. 10A PC board type

External dimensions

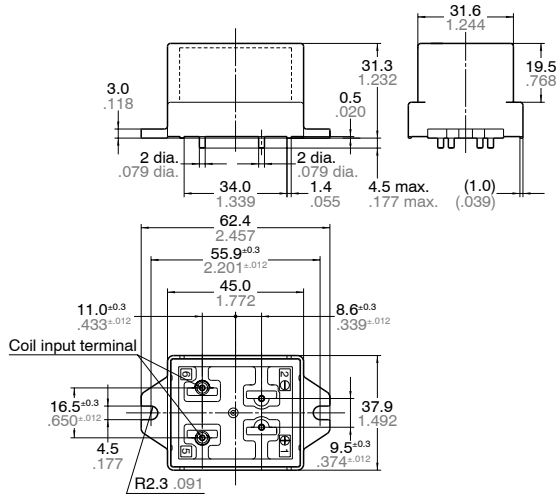

Schematic (Bottom view)

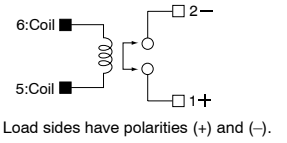

PC board pattern (Bottom view)

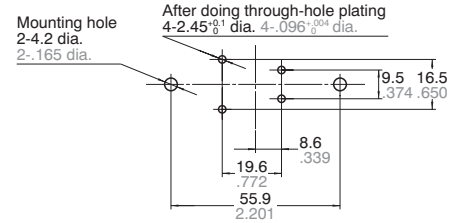

- Notes:
1. We recommend through-hole plating with land on both sides.
  2. Be careful of the insulation distance between land patterns with regards to the circuit voltage you will use.

**General tolerance:**

- less than 10 .394 ±0.3 ±.012
- 10 .394 to 50 1.969 ±0.6 ±.024
- more than 50 1.969 ±1.0 ±.039

## 2. 10A TM type

External dimensions

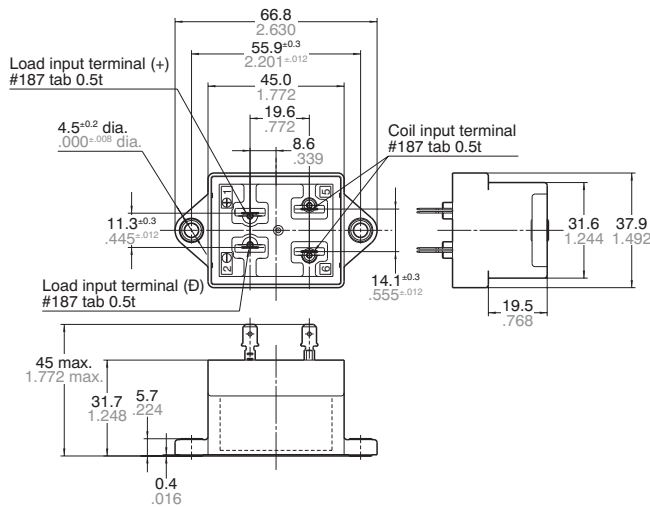

Schematic (Top view)

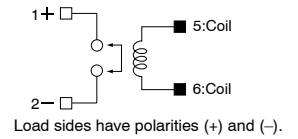

Panel cut-off

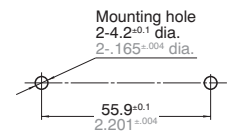

**General tolerance:**

- less than 10 .394 ±0.3 ±.012
- 10 .394 to 50 1.969 ±0.6 ±.024
- more than 50 1.969 ±1.0 ±.039

3. 60A type

External dimensions

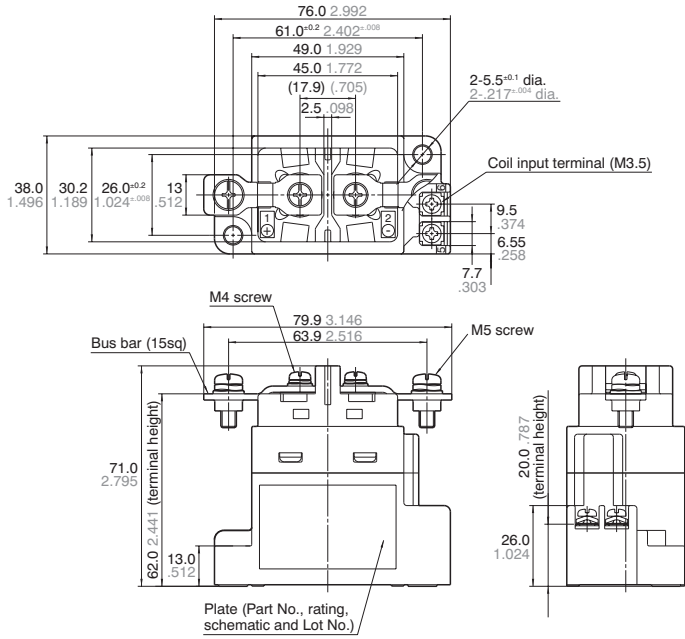

Schematic (Top view)

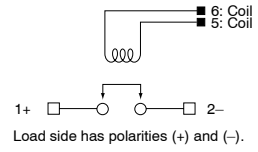

Panel cut-off

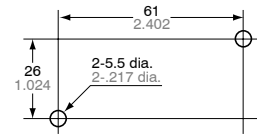

General tolerance:

- less than 10 .394 ±0.3 ±0.12
- 10 .394 to 50 1.969 ±0.6 ±0.24
- more than 50 1.969 ±1.0 ±0.39

4. 80A type

External dimensions

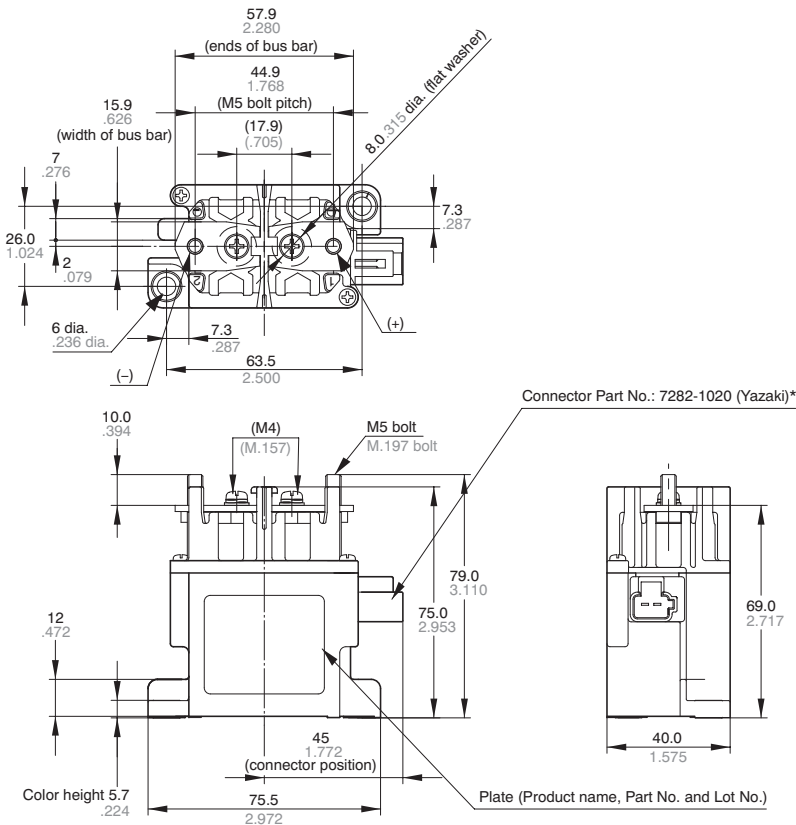

Schematic (Top view)

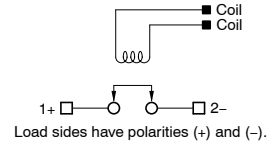

Panel cut-off

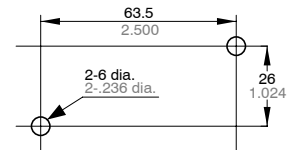

\*Accessories (included)

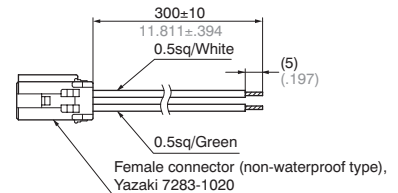

General tolerance:

- less than 10 .394: ±0.3 ±0.12
- 10 .394 to 50 1.969: ±0.6 ±0.24
- more than 50 1.969: ±1.0 ±0.39

5. 300A type

External dimensions

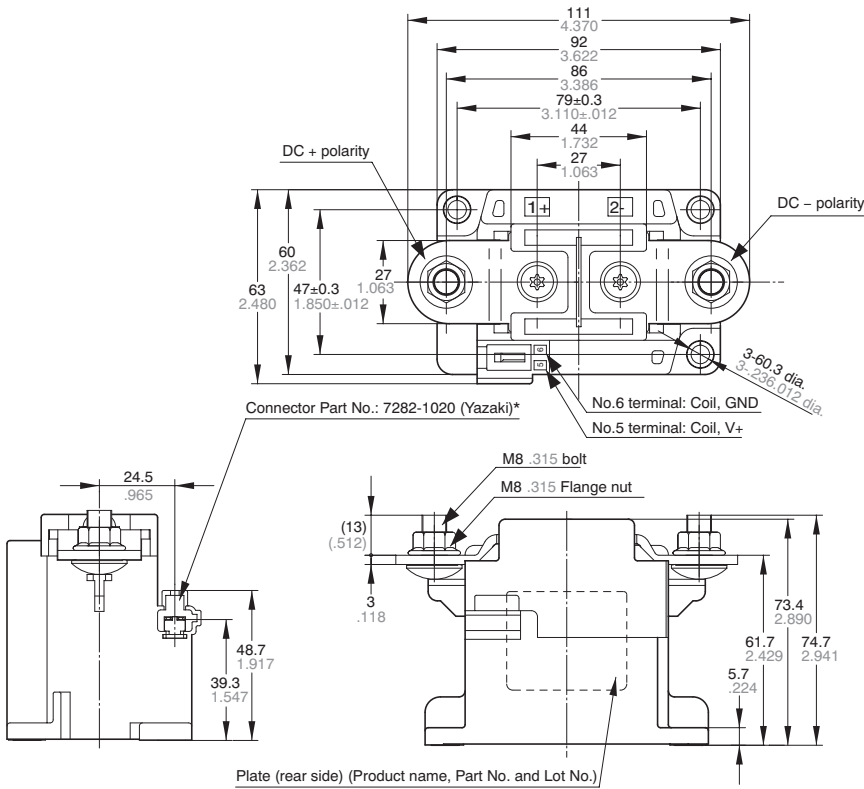

Schematic (Top view)

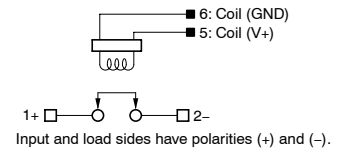

Panel cut-off

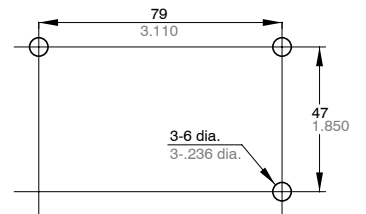

\*Accessories (included)

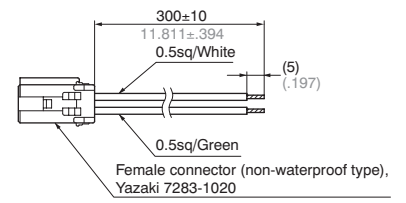

General tolerance:

- less than 10 .394: ±0.3 ±.012
- 10 .394 to 50 1.969: ±0.6 ±.024
- more than 50 1.969: ±1.0 ±.039

## NOTES

### 1. When installing the relay, always use washers to prevent the screws from loosening.

Tighten each screw within the rated range given below. Exceeding the maximum torque may result in breakage. Mounting is possible in either direction.

- M5 screw (60A, 80A and 300A main unit mounting section): 3 to 4N·m
- M3.5 screw (60A input terminal): 0.84 to 1.2 N·m
- M4 screw (10A PC board type main unit mounting section): 0.98 to 1.2N·m (10A TM type main unit mounting section): 1.8 to 2.7N·m

Recommended securing torque on load side terminals

- 60A/M5 screw: 2.5 to 3.6 N·m
- 80A/M5 bolt: 3.5 to 6.5 N·m
- 300A/M8 bolt: 10 to 12 N·m

### 2. The contacts of the relay are polarized. Please follow instructions in the connection schematic when connecting the contacts.

We recommend installing a surge protector varistor (ZNR) for the 10A, 60A and 80A types. Avoid using a diode as this may result in decreased cut-off capability.

### 3. Do not use a relay if it has been dropped.

### 4. Avoid mounting the relay in strong magnetic fields (near a transformer or magnet) or close to an object that radiates heat.

### 5. Electrical life

This relay is a high-voltage direct-current switch. In its final breakdown mode, it may lose the ability to provide the proper cut-off. Therefore, do not exceed the indicated switching capacity and life. (Please treat the relay as a product with limited life and replace it when necessary.)

In the event that the relay loses cut-off ability, there is a possibility that burning may spread to surrounding parts, so configure the layout so that the power is turned off within one second and from the point of view of safety, consider installing a failsafe circuit in the device.

Also, in order to avoid increased contact resistance, do not operate when there is no switching load.

### 6. Permeation life of internal gas

This relay uses a hermetically encased contact (capsule contact) with gas inside. The gas has a permeation life that is affected by the temperature inside the

capsule contact (ambient temperature + temperature rise due to flow of electrical current). For this reason, make sure the ambient operating temperature is between  $-40$  and  $80^{\circ}\text{C}$   $-40$  and  $+176^{\circ}\text{F}$ , and the ambient storage temperature is between  $-40$  and  $85^{\circ}\text{C}$   $-40$  and  $+185^{\circ}\text{F}$ .

### 7. Do not disassemble the relay.

**Please note that disassembling the relay will invalidate the warranty.**

8. If the power is turned off and then immediately on after applying the rated voltage (current) continuously to the relay's coil and contact, the resistance of the coil will increase due to a rise in the coil temperature. This causes the pick-up voltage to rise, and possibly exceed the rated pick-up voltage. In these circumstances, take measures such as reducing the load current, limiting the duration of current flow, and applying a coil voltage higher than the rated operating voltage.

### 9. Coil operating power

Pure DC current should be applied to the coil. The wave form should be rectangular. If it includes ripple, the ripple factor should be less than 5%. However, check the actual circuit since the characteristics may be slightly different. The power supply waveform supplied to the coil should be rectangular.

**10. Don't exceed maximum coil voltage. Exceeding maximum allowable coil voltage on continuous basis will damage the relay and could cause failure.**

**11. Ensure that the rated contacts voltage and current values are not exceeded.**

**12. The rated control capacity and life are given as general guides.**

The contact life is heavily influenced by the type of load and other related conditions, and these factors must be kept in consideration when using the relay.

**13. Main contact ratings in the ratings apply to when there is a resistive load.**

**If you are using an inductive load (L load) such that  $L/R > 1$  ms, add surge protection in parallel with the inductive load. If this is not done, the electrical life will decrease and cut-off failure may occur.**

**14. Be careful that foreign matter and oils and fats kind don't stick to the main terminal parts because it is likely to cause terminal parts to give off**

**unusual heat. Also, please use the following materials for connected harnesses and bus bars.**

- 10A TM type: Faston terminal for #187 tab terminal, 0.5 mm board thickness (JIS C2809-1992 compliant, flat type connection terminal)  
Harness nominal cross-sectional area  
Load input terminal: min. 2.0 mm<sup>2</sup>  
Coil input terminal: min. 0.3 mm<sup>2</sup>
- 60A and 80A types: Min. 14mm<sup>2</sup> nominal cross sectional area
- 300A type: Min. 100mm<sup>2</sup> nominal cross sectional area

**15. Use 40N to 70N of force as a guide to fasten the terminal connected to the 10A TM type. Please use caution when inserting or removing the terminal as the relay tab terminal may cause injury.**

**16. Place the PC board mount type (10A PC board type) securely by hand soldering after attaching it using M4 screw. Don't submerge assembled board in cleaning solvent or water. Also, be careful not let flux overflow up from the PC board or adhere to the base of the relay.**

Recommended hand soldering conditions

- Soldering iron: 30 to 60 W
- Tip temperature:  $400^{\circ}\text{C}$   $752^{\circ}\text{F}$
- Solder time: within approx. 5 seconds

**17. Make sure the power is turned off when wiring.**

**18. Incorrect wiring may cause unexpected malfunction and failure.**

**19. Regarding AC cutoff, although there is no contact polarity, generally it is thought that the electrical life will shorten due to cutoff in the reverse direction, compared to DC cutoff.**

**Confirm electrical life using actual load. In the case of DC cut-off, please note the contact polarity.**

**20. Lead-free solder (tin, silver and copper) is used as pre-solder for the terminals of the PC board mount type (10A PC board type).**

**21. The warranted tensile strength of the female connector lead wire used for connection that comes with the 80A and 300A connector type when attaching it to the relay body is 100N. Avoid excessive tension as this is a cause of broken wires and damage. Also, insert the female connector deeply and make sure the connection is secure.**

**For Cautions for Use, see [Relay Technical Information](#).**